

# CREATING SHEET PARTS – SHEET CONNECTION OF PROFILES

## SKEW ROLLER

Model sheet cooper part of roller by the pattern.

Thickness of sheet is 0.8 mm.

Apertures diameter is 50 mm.

Make unrolling of the part.

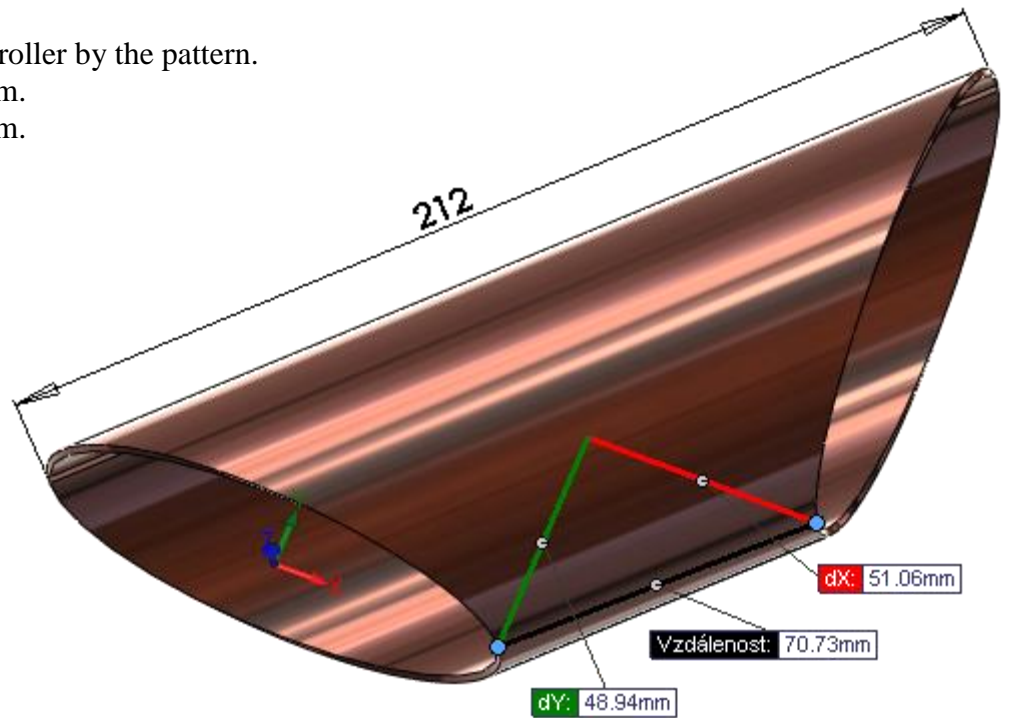

## KETTLE

Model “Kettle” from the same sheet, its parameters must correspond to lengths of arc and height of model in the pattern. Make unrolling of the part.

