

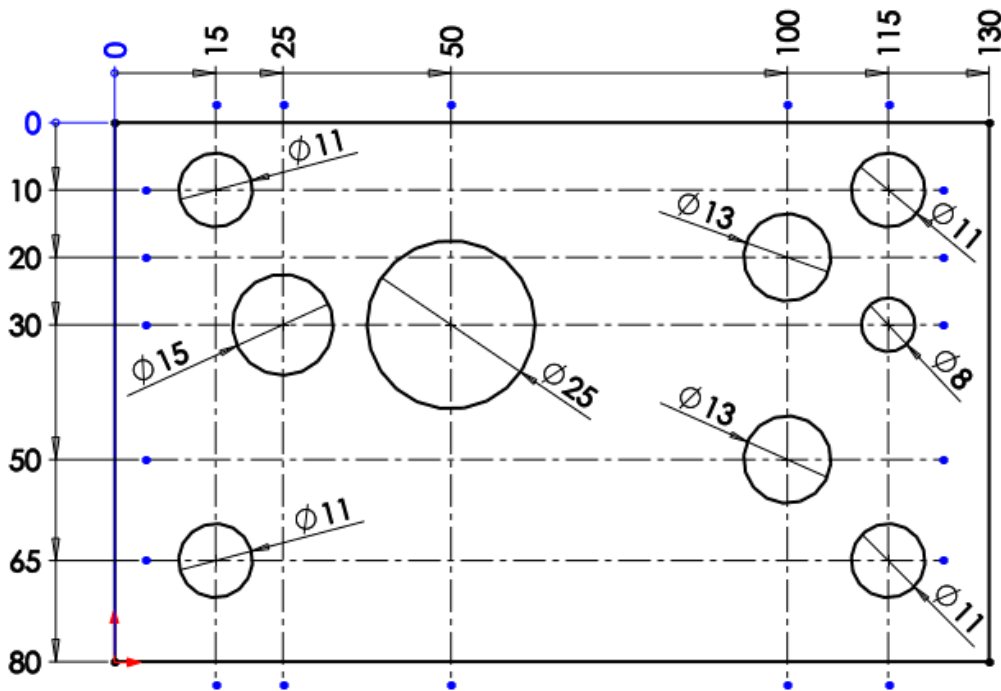

**THE PLATE WITH APERTURES**

Dimension a plate for CNC production with vertical and horizontal coordinate dimension by the model. Make it in the front sketch plain. Its thickness is 5 mm.



**OPENER**

Make the model of opener made on CNC machines and because of it needs coordinate dimensioning. Thickness of the part is 5 mm. Make it in the front sketch plain.

