

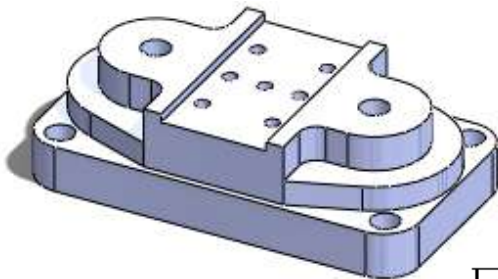

Vytvořte zadané modely samostatně podle výkresových předloh! Pro každý model nakreslete pouze jednu skicu v jedné základní rovině, která bude obsahovat co nejvíce uzavřených profilů.

DRŽÁK



ŘEZ A - A

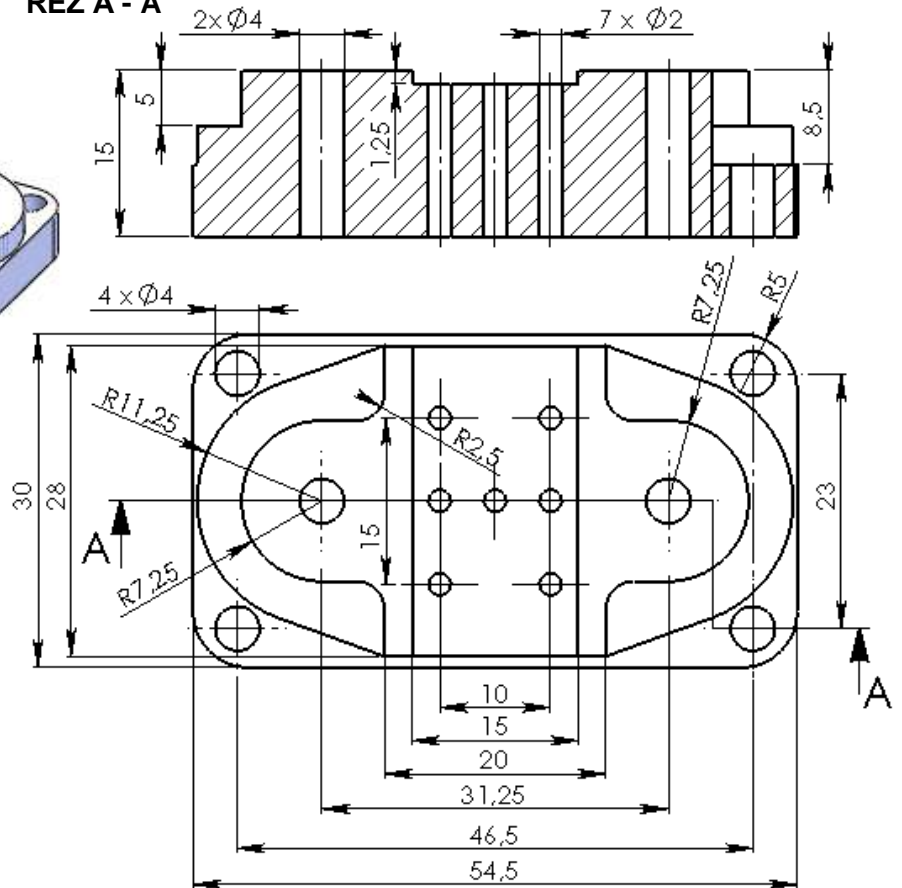

DRAŽKY

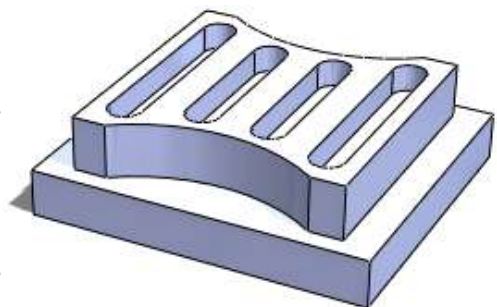
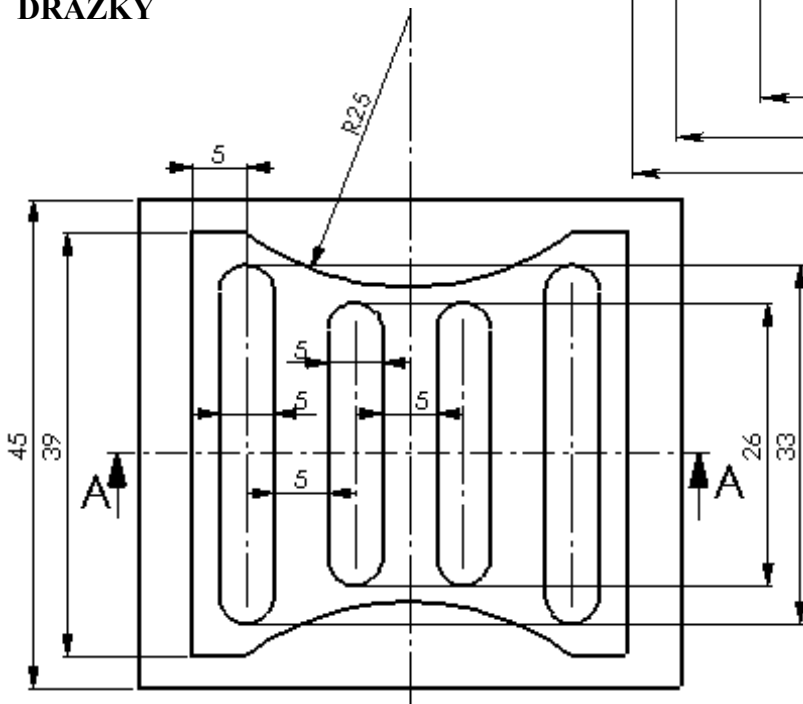

ŘEZ A - A

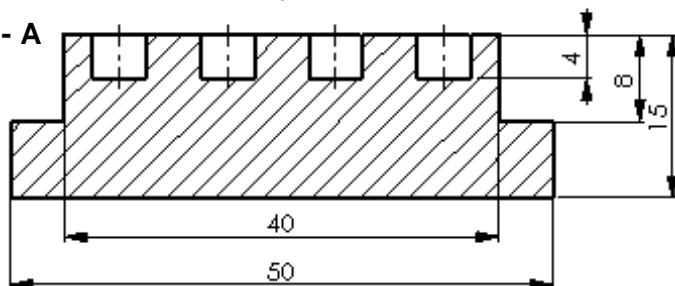



OZDOBA

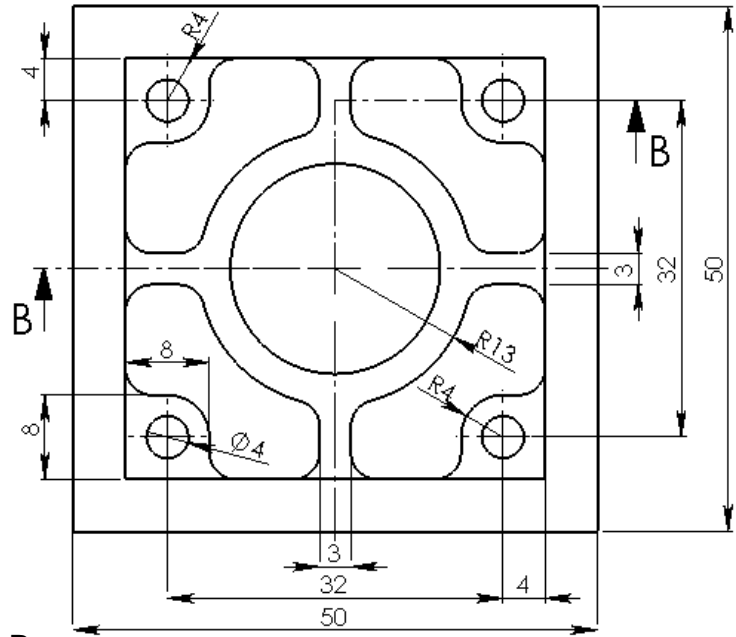
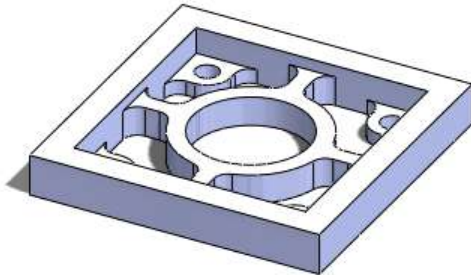

ŘEZ B - B

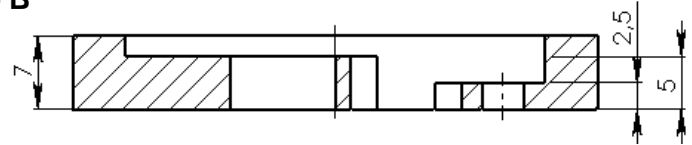

DESKA POD VÍKO

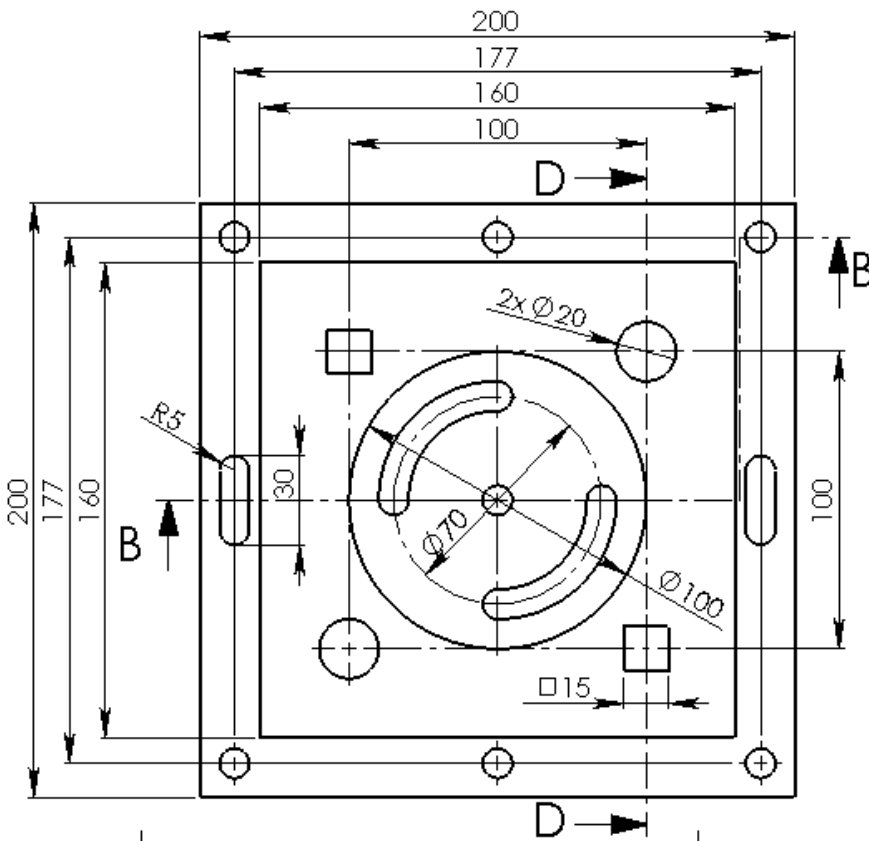

ŘEZ B - B

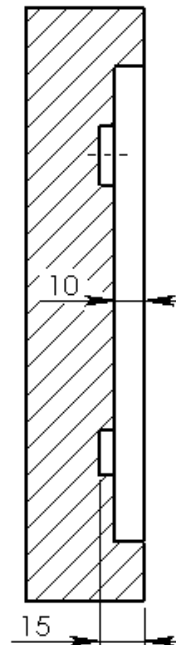

ŘEZ D - D

