

Make independently these parts by the drawing patterns.

HELIX

The line for drawing is the helix in two revolutions with rising 80 mm. Set the initial angle 0°.

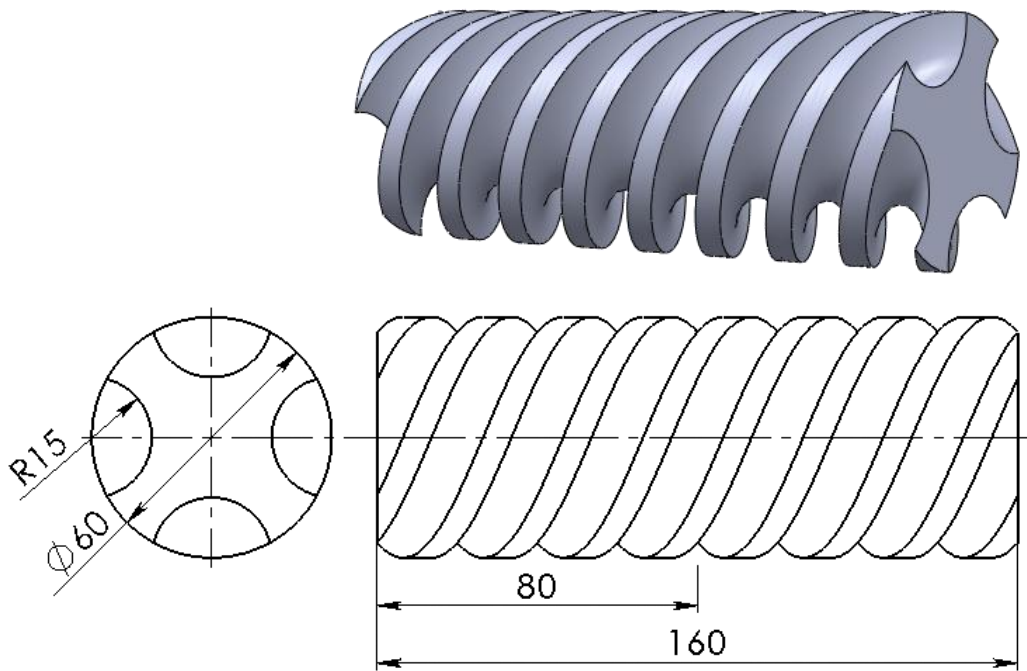

ARC V PROFILE

For construction of the part use one profile drawing onto two lines. Each of these lines creates independent quarter of the circle.

